

Hydroware products available from Hydratec

HYDROELITE® VENI & VIDI

INTEGRATED DRIVE AND CONTROL SYSTEM FOR HYDRAULIC LIFTS



HydroElite® VENI

Integrated drive and control system for hydraulic lifts

HydroElite Veni is equipped with the unique valve Dynahyd from Hydroware, which means short reaction times, no by-pass of the oil and travels with direct approach to the floor, without creeping.

The lift gets the absolute best features for an electronically controlled valve and soft starter, and can only be compared to frequency controlled systems today.

With the same manufacturer for both drive and control system you get fast and smooth order handling, quick installation, easy inspection, reliable final product, same support contact for both drive and control unit and a satisfied passenger.

HydroElite Veni is certified according to EN81-20/50 and also has a common certificate for A3/UCM.

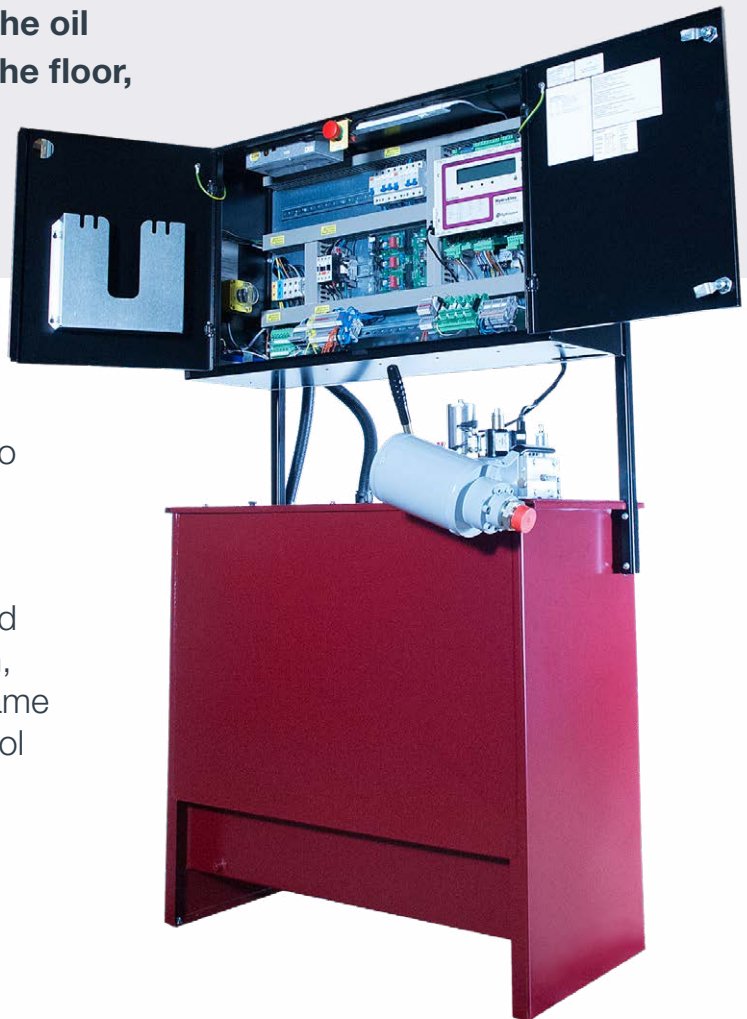

FEATURES/BENEFITS*

- Quick installation
- Direct approach to floor
- Self-learning and no manual adjustments
- Test of system before delivery
- EN81-20/50 certified
one common UCM certificate for both triggering and stopping devices
- Energy consumption cut with up to 50%
- Unique servo valve (no by-pass oil)
- Soft-starter
- Submerged motor

VERSION MINI



HYDROELITE® VENI SPECIFICATION AT DIFFERENT LOADS*

Example Speed: 0.63m/s | Floors: 4 | Journeys per year: 100,000

Load (kg)	Isolator (A)	Starts (per hour)	Motor (kW)	Pressure min/max (bar)	Energy consumption (kWh)
630	25	100	9.5	10-50	2100
1000	35	80	14.7	10-50	3100

HYDROELITE® VENI SPECIFICATION AT DIFFERENT LOADS*

Example Speed: 0.63m/s | Floors: 4 | Journeys per year: 100,000

Dimensions

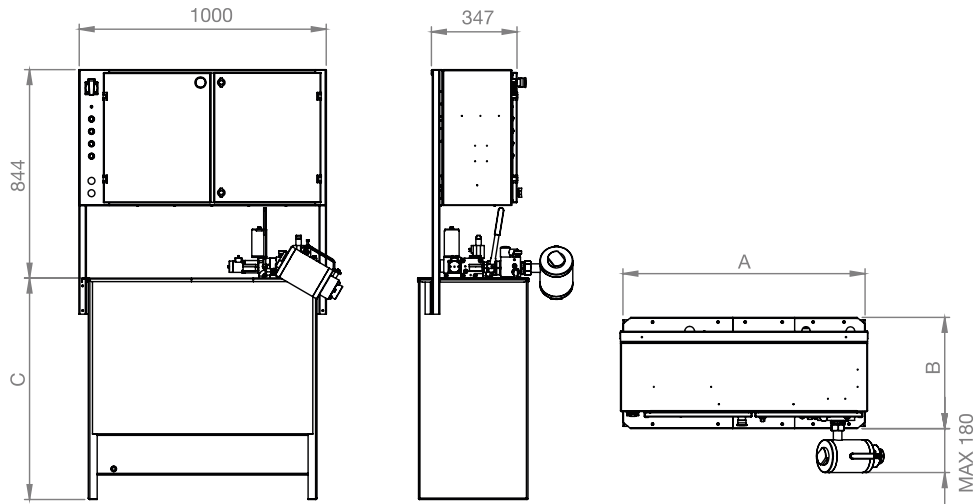

Tank	Pump (l/min)	Valve size	Dimensions			Weight of unit without oil (kg)	Oil volume (l)	
			A	B	C		Max	Useful
230	55-210	1 1/4"	980	450	900	250	230	160
400	55-210	1 1/4"	1100	615	1000	300	400	300
400	250-440	2"	1100	615	1000	300	400	300
700	250-800	2"	1360	750	1000	390	700	460

Variant with separate wall-mounted cabinet

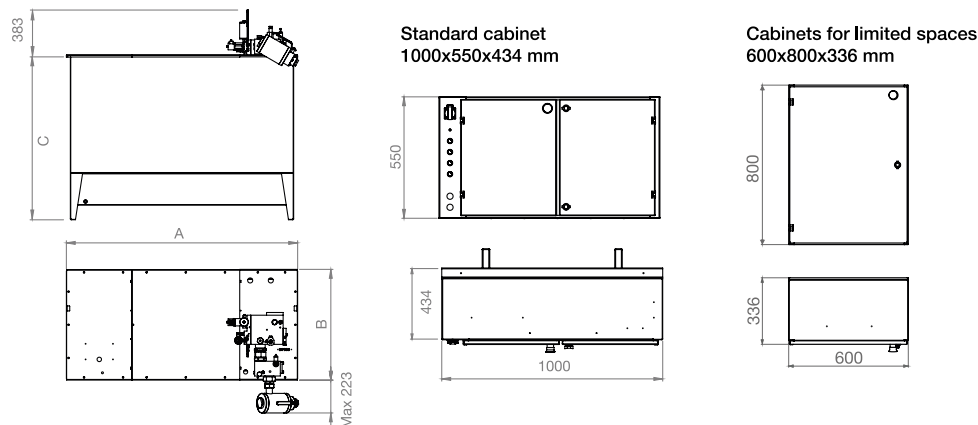

Tank	Pump (l/min)	Valve size	Dimensions			Weight of unit without oil (kg)	Oil volume (l)	
			A	B	C		Max	Useful
950	250-800	2"	1570	750	1120	450	950	665
1200	250-800	2"	1750	850	1120	520	1200	700

HydroElite® VIDI

Integrated drive and control system for hydraulic lifts

With HydroElite Vidi the problem with big power demand is eliminated.

By accepting that an elevator trip upwards with full load, goes a little slower than the nominal speed, power demand can be reduced as much as up to 70% compared to other systems on the market.

The effective air cooled motor means that the energy consumption will be cut with another 20%, compared to HydroElite Veni.

The other advantages, thanks to the unique valve Dynahyd, are also experienced with the HydroElite Vidi.

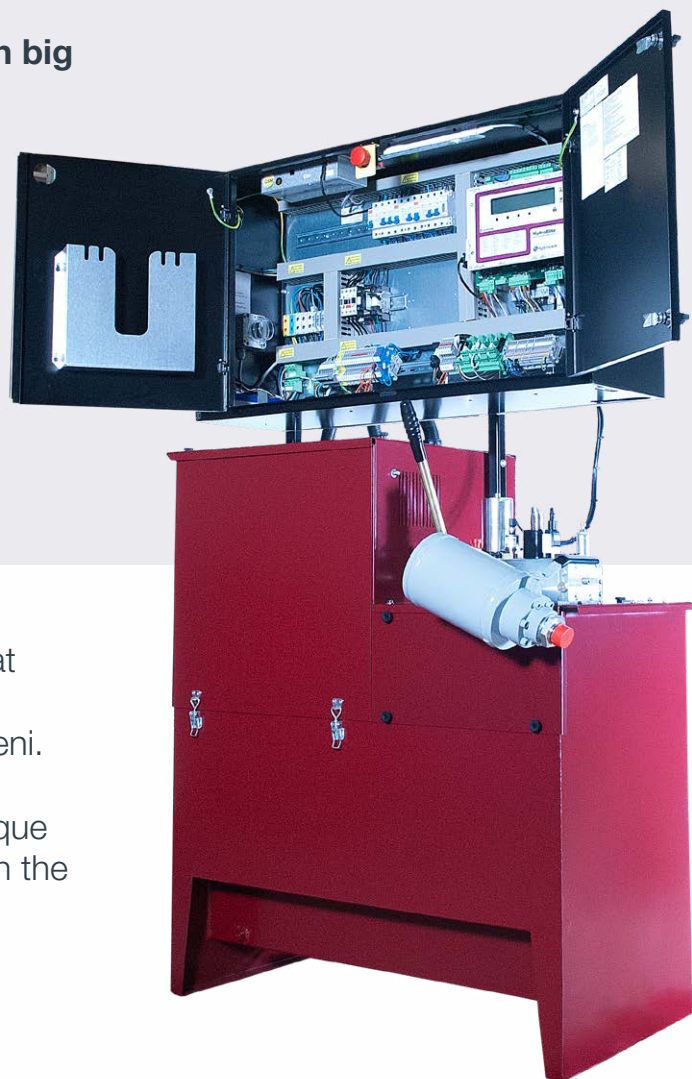

FEATURES/BENEFITS*

- Quick installation
- Direct approach to floor
- Self-learning and no manual adjustments
- Test of system before delivery
- EN81-20/50 certified
one common UCM certificate for both triggering and stopping devices
- Energy consumption cut with up to 70%
- Power demand cut by 50–70%
- Unique servo valve (no by-pass oil)
- Frequency inverter
- Air cooled IE2 motor

VERSION MRL



HYDROELITE® VIDI SPECIFICATION AT DIFFERENT LOADS*

Example Speed: 0.63m/s | Floors: 4 | Journeys per year: 100,000

Load (kg)	Isolator (A)	Starts (per hour)	Motor (kW)	Inverter (kW)	Pressure min/max (bar)	Energy consumption (kWh)
630	16	120	7.5	5.5	10-50	1700
1000	16	95	11	7.5	10-50	2500

HYDROELITE® VIDI SPECIFICATION AT DIFFERENT LOADS*

Example Speed: 0.63m/s | Floors: 4 | Journeys per year: 100,000

Dimensions

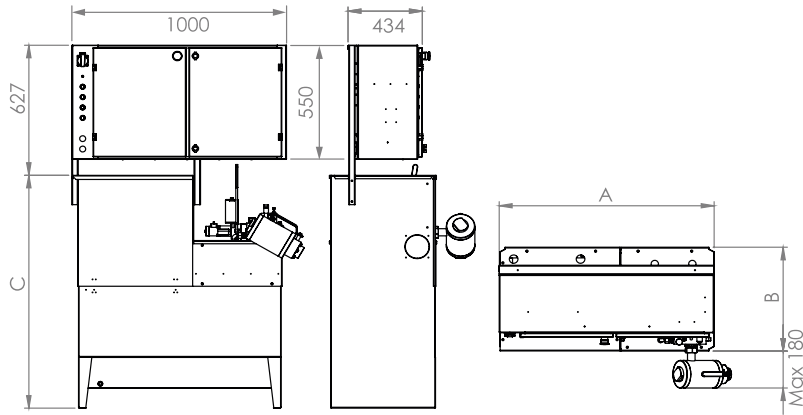

Tank	Pump (l/min)	Motor (kW)	Valve size	Dimensions			Weight of unit without oil (kg)	Oil volume (l)	
				A	B	C		Max	Useful
150	45-150	4-15	1 1/4"	1003	500	1122	250	150	62-98
190	45-150	4-15	1 1/4"	1003	600	1122	260	190	77-121
290	180-330	11-22	2"	1205	600	1222	290	290	95-215

Variant with separate wall-mounted cabinet

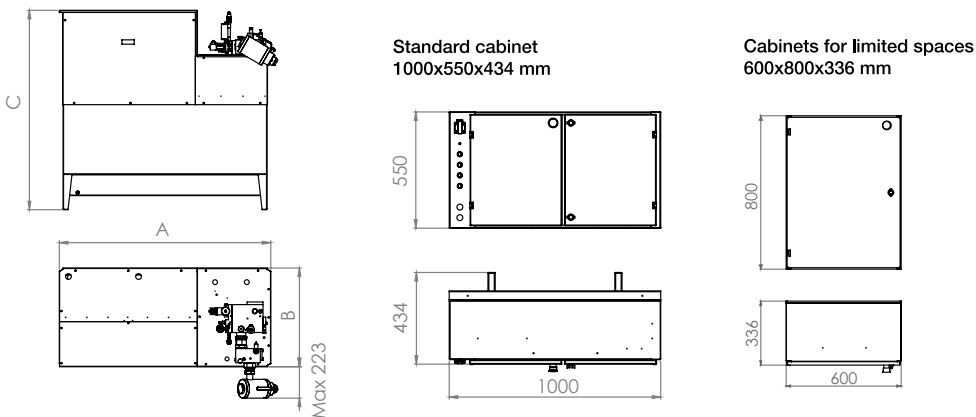

Tank	Pump (l/min)	Motor (kW)	Valve size	Dimensions			Weight of unit without oil (kg)	Oil volume (l)	
				A	B	C		Max	Useful
475	150-600	15-45	2"	1500	700	1415	360	475	345
590	150-600	15-45	2"	1500	700	1515	400	575	440
975	180-600	15-55	2"	1900	900	1600	550	975	455-720
Extra Tank	-	-	-	1000	800	850	150	400-475	

Unique valve

HydroElite Veni and Vidi are equipped with the unique valve, Dynahyd from Hydroware.

With short reaction times, no by-pass oil and direct approach to floor without creeping the lift gets the absolutely best features that can be obtained with an electronically controlled valve and soft starter.



Integrated system

The main product from Hydroware is the HydroElite.

It is a drive and control system for hydraulic lifts which are fully tested in our production before delivery and is therefore prepared for a quick installation. As the drive and control system comes from the same supplier, good functionality and simple handling is secured regarding support, maintenance and warranties.



Hydratec Lift Services Limited
Unit 1B, Blackbushe Business Village
Yateley, Hampshire
GU46 6GA

t · +44 (0) 1252 871664
f · +44 (0) 1252 873601
e · sales.south@hydratec-lifts.co.uk

Hydratec Lift Services Limited
Unit A5, Axis Point Harehill Business Park
Hill Top Road, Heywood
OL10 2RQ

t · +44 (0) 1252 871664
f · +44 (0) 1252 873601
e · sales.north@hydratec-lifts.co.uk

